

■ MINI SPIDER | FILLET WELDING TRACTOR

The Mini Spider is a battery-powered welding tractor designed to produce continuous fillet welds using MIG/MAG torches. The torch can be easily swapped from one side of Mini Spider to another.

4-wheel drive system with magnetic traction and a feedback loop provides highly efficient speed stabilization. Constant, continuous and repeatable travel speed enables weld bead geometry that is exact to the required specifications, thus reducing costly over welding and substantially decreasing filler metal usage.

■ Features and benefits:

- Compact and lightweight design to weld in narrow spaces
- Convenient 18 V DC battery supply (the same battery for both Mini Spider and Gecko Battery)
- Torch placement on either side
- Welding edge to edge
- Closed-loop speed control system based on electric motor with encoder – ensures increased speed accuracy
- Consistent heat input reduces distortion
- Reduces wasted filler metal – eliminates over welding
- Digital LED display for presetting of travel speed and diagnostic messages
- Low-battery indicator
- Built-in guide rollers



■ New control system of battery pack:

Detection and supervised parameters:

- too low and too high voltage
- too low and too high temperature
- failure of the temperature sensor
- internal battery failure

Benefits:

- over discharge protection
- extended battery life
- high level of safety for both tractor and operator



Torch placement on either side

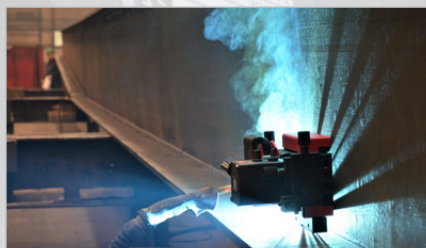

Welding edge to edge

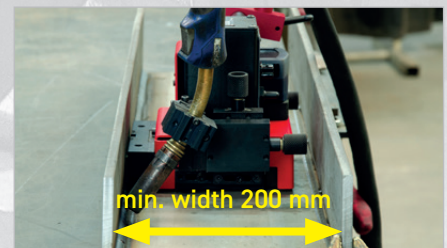

Welding in narrow spaces



Continuous welding



Horizontal speed
5-110 cm/min



Torch placement
on either side



Welding in
narrow spaces



Weight
7,6 kg

MINI SPIDER Technical Specification

Voltage	18 V DC, 4.0 Ah
Power	25 W
Welding position (according to EN ISO 6947 and AWS/ASME)	PB / 2F PA / 1F
Torch diameter	16-22 mm (0.63-0.87")
Min. workpiece thickness	4 mm (0.16")
Ground clearance	4 mm (0.16")
Horizontal pulling force	150 N
Horizontal speed *	5-110 cm/min (2-43.3 in/min)
Cross slide adjustment range	0-21 mm (0-0.83") up down, left-right
Weight (w/o battery)	7.6 kg (16.8 lbs)
Product code	WOZ-0735-10-00-00-0

* With battery fully charged

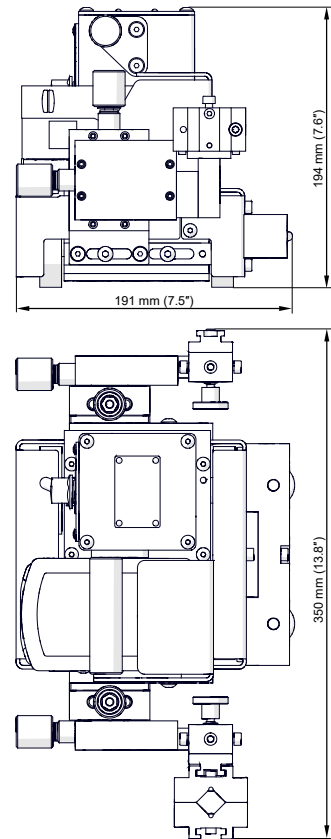

Standard accessories:



Torch holder
ZCS-0270-42-00-00-0



Battery 4.0 Ah
AKM-0738-10-00-01-0
(2 pcs included)



Battery Charger
LDW-0738-10-00-30-0 (EU)
LDW-0738-06-00-30-0 (AUS/NZ)
LDW-0738-04-00-30-0 (UK)



Cable anchor
UCW-0655-08-00-00-0



Auxiliary magnet blocks
ZST-0655-09-00-00-0



Torch placement on either side



Standard shipping set:

- Mini Spider tractor
- Foam-filled cardboard box
- Battery 4.0 Ah (2 pcs)
- 4 mm hex wrench
- 3 mm hex wrench
- Operator's Manual



American Welding Society
Supporting Company Member

Mitglied im DVS - Deutscher Verband für
Schweißen und verwandte Verfahren e. V.



More information on www.promotech.eu



PROMOTECH Sp. z o.o.
ul. Elewatorska 23/1, 15-620 BIAŁYSTOK, POLAND
tel. (+48 85) 678 34 05, fax (+48 85) 662 78 77
marketing@promotech.eu www.promotech.eu

Your local dealer:

